

CASE STUDY RESEARCH FACILITY



MARCRRAFT
CUSTOM HVAC SYSTEMS

MARCRRAFT CUSTOM HVAC SYSTEMS SERVE THE LIFE OF RESEARCH

APPLICATION:..... Toxicological Research Facility

LOCATION:..... Arkansas

CUSTOM HVAC SYSTEM SIZE:..... 16,000 CFM SUPPLY AIR, 16,000 CFM EXHAUST AIR

MARCRRAFT TOTAL SOLUTION

The facility modifies specific rooms to fit the requirements of the research project. Custom units are ordered to serve this space and are expected to stay functional throughout the life of the research project. Should the unit fail, changing the conditions of the building space, it could ruin the research project causing them to have to restart the project and lose years of valuable research.

INDOOR HVAC SYSTEM SPECIFICS: CONSTRUCTION

- 4" double wall casing w/ 1.5 pcf fiberglass insulation and Thermal Break. Unit is Galv Steel except for perforated stainless steel in the coil/discharge section.
- Unit Base is 6" Structural C-Channel w/ C-Channel Cross bracing fully welded. 6" of Fiberglass insulation
- Floor is 12 ga Galvanized Steel. Floor is fully welded.
- The unit is constructed with an upper and lower sections for the split SA/EA air tunnels.
- Unit ships in 3 sections.

NOTEWORTHY

- MarCraft has multiple units at the facility in Arkansas
- MarCraft was basis of design for this project working closely with the specifying engineer to select a unit to fit in the space allotted and provide the performance required.

SPECIFICATIONS

- 16,000 CFM Supply Air, 16,000 CFM Exhaust air
- Unit providing 100% Outside Air
- Plate to Plate Heat Exchanger
- Desaturation Dehumidification Coil



MARCRRAFT
CUSTOM HVAC SYSTEMS

(800) 325-1303

11880 Dorsett Road,
St. Louis, MO 63043

MarCraftHVAC.com

CASE STUDY RESEARCH FACILITY

1. OA Damper
2. Pre-Filter Bank
3. Supply Fan Assembly
4. Bypass Damper
5. Heat Exchanger Face Damper
6. Heat Exchanger
7. Return Fan Assembly
8. EA Damper
9. RA Damper
10. Hot Water Heating Coil Bank
11. Desaturation Coil Bank
12. Final Filter Bank
13. Piezometer Tubing J-Box
14. Disconnect
15. Perforated Sound Panels

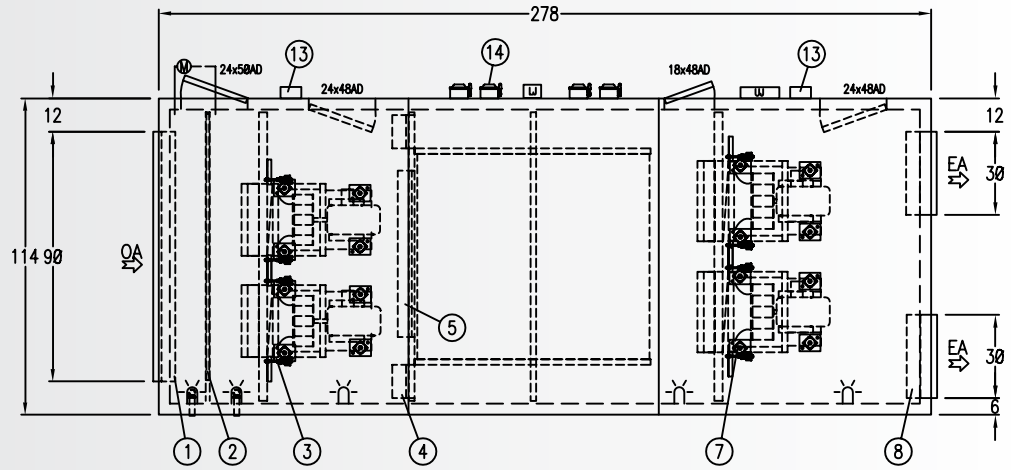

PLAN VIEW

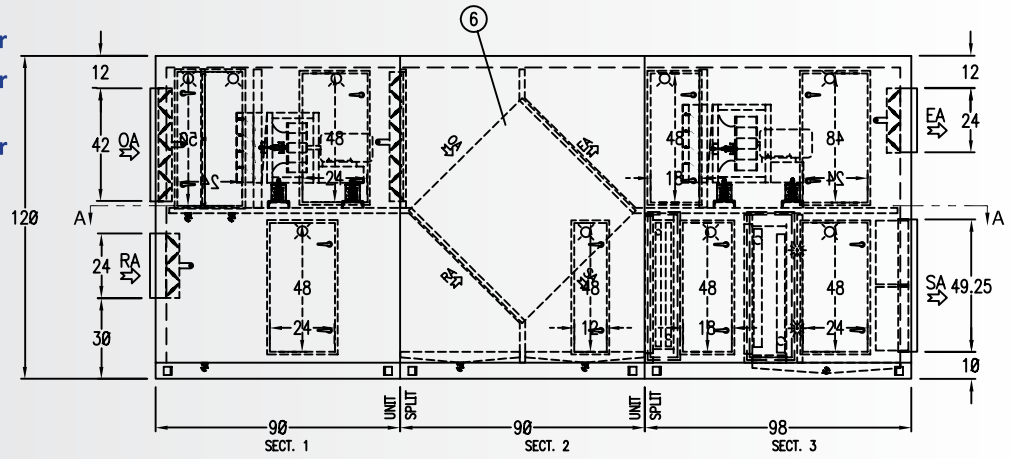

ELEVATION VIEW

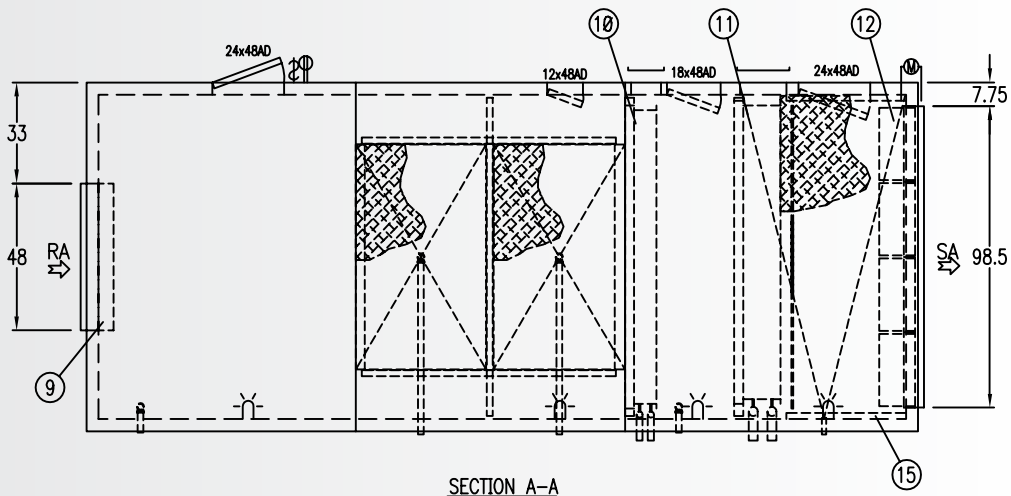

SECTION A-A

COMPONENTS

SUPPLY AIR TUNNEL

- OA Inlet Damper
- 2" Pre-filter in Side Access frame
- Two SA fans with isolation back-draft dampers
- Plate to Plate Heat Exchanger with Face and Bypass Dampers
- Heating Coil Assemblies – Hot Water Coil
- Cooling Coil Assemblies – Desaturation Coil with UV Lights
- HEPA Filters at the SA discharge opening.

EXHAUST AIR TUNNEL

- RA Inlet Damper
- Plate to Plate Heat Exchanger
- Two EA fans with isolation back-draft dampers Factory Testing
- EA Discharge Damper



MARCRRAFT
CUSTOM HVAC SYSTEMS

(800) 325-1303

11880 Dorsett Road,
St. Louis, MO 63043

MarCraftHVAC.com